

# The $hp$ Finite Element Method For Singularly Perturbed Problems in Nonsmooth Domains

Christos Xenophontos

Department of Mathematics and Computer Science  
Clarkson University  
Potsdam, New York 13699-5815

Received January 21, 1998; accepted May 18, 1998

We consider the numerical approximation of singularly perturbed elliptic boundary value problems over nonsmooth domains. We use a decomposition of the solution that contains a smooth part, a corner layer part and a boundary layer part. Explicit guidelines for choosing mesh-degree combinations are given that yield finite element spaces with robust approximation properties. In particular, we construct an  $hp$  finite element space that approximates all components uniformly, at a near exponential rate. © 1999 John Wiley & Sons, Inc. Numer Methods Partial Differential Eq 15: 63–?? , 1999

*Keywords:* Finite element method;  $hp$  version; singularly perturbed problems

## I. INTRODUCTION

It is well known that for elliptic problems over nonsmooth domains, singular components are introduced in the solution in neighborhoods of the corners. For *singularly perturbed* problems, boundary layers arise in addition to corner singularities. *Boundary layers* are rapidly varying solution components that have support in a narrow neighborhood of the boundary of the domain. Such problems arise in the study of plates and shells in structural mechanics and in heat transfer problems with small thermal coefficients.

In this article, we study the numerical approximation of a singularly perturbed elliptic problem over a *square*, in the context of the  $hp$  finite element method. In [?] it was shown that the solution can be decomposed into a smooth part, a boundary layer part, a corner layer part, and a smooth remainder. We show that the boundary layer part of the solution is essentially of the form

$$u_{BL}(x, y) = C(x) \exp(-y/\varepsilon), \quad (1.1)$$

with  $C(x)$  smooth and  $\varepsilon \in (0, 1]$ . This indicates that the boundary layer effect is essentially one-dimensional. In [?] one-dimensional boundary layers were studied in detail and an  $hp$  finite element scheme was presented with robust, exponential convergence properties. In [?], functions

of the type (??) were studied, and the results of [?] were used for their approximation over *smooth* domains. (See also [?], [?] for recent developments in the approximation of such problems in smooth domains). In the present case, the nonsmoothness of the domain further complicates the approximation, due to the presence of corner singularities. Using the results of [?] for the approximation of the corner layers, we are able to construct finite element spaces that approximate *both* the corner layers *and* the boundary layers. We obtain near-exponential (spectral) rates in the *energy norm* that are uniform with respect to the perturbation parameter  $\varepsilon$ .

In Section II, we present the model problem and the asymptotics of its solution from [?]. In Sections III, IV, and V, we discuss the approximation of the boundary layers, corner layers, and smooth part, respectively; and in Section VI, we present our main result. Finally, in Section VII, we present the results of numerical computations that are observed to agree well with our estimates.

Throughout this article,  $H^k(\Omega)$  denotes the Sobolev space of order  $k \in \mathbb{N}_0$  on a domain  $\Omega \subset \mathbb{R}^2$ , with  $H^0(\Omega) = L^2(\Omega)$ , and  $\|\cdot\|_{k,\Omega}, |\cdot|_{k,\Omega}$  denoting the norm and seminorm as usual. Whenever there is no confusion, we omit the subscript  $\Omega$ . The set  $C^n(\Omega)$  denotes continuous functions with  $n$  continuous derivatives, and  $\Pi_p(\Omega)$  denotes the set of polynomials of degree  $\leq p$  in each variable, over  $\Omega$ . The letters  $K, C$  (without any dependencies on variables) are used to denote generic positive constants, possibly not the same in each occurrence.

## II. MODEL PROBLEM

We consider the singularly perturbed elliptic boundary value problem

$$\begin{aligned} -\varepsilon^2 \Delta u + u &= f \text{ in } \Omega := (0, 1)^2, \\ u &= 0 \text{ on } \partial\Omega, \end{aligned} \quad (2.1)$$

where  $\varepsilon \in (0, 1]$  is a small parameter and  $f(x, y)$  is *analytic*. Its weak formulation is: Find  $u \in H_0^1(\Omega)$  such that

$$B(u, v) := \varepsilon^2 (\nabla u, \nabla v) + (u, v) = (f, v) \quad \forall v \in H_0^1(\Omega), \quad (2.2)$$

where  $(\cdot, \cdot)$  denotes the usual  $L^2$  inner product. Since  $B(u, v) \geq \varepsilon^2 \|u\|_{1,\Omega}^2$ , problem (??) admits a unique solution for every  $0 < \varepsilon \leq 1$ . We denote by

$$\|u\|_{\varepsilon,\Omega} = (B(u, u))^{1/2}, \quad 0 < \varepsilon \leq 1 \quad (2.3)$$

the *energy norm* corresponding to (??).

The finite element approximation of (??) proceeds as usual: given a subspace  $S_N \subset H_0^1(\Omega)$  of dimension  $N$ , the finite element solution  $u_N \in S_N$  satisfies

$$B(u_N, v) = (f, v) \quad \forall v \in S_N. \quad (2.4)$$

Again, for every  $0 < \varepsilon \leq 1$ , there exists a unique solution  $u_N \in S_N$  and

$$\|u - u_N\|_{\varepsilon,\Omega} = \inf_{v \in S_N} \|u - v\|_{\varepsilon,\Omega}. \quad (2.5)$$

Our goal in this article is the design of a finite element space  $S_N$  such that

$$\|u - u_N\|_{\varepsilon,\Omega} \leq CF(N),$$

with  $F(N) \rightarrow 0$  as  $N \rightarrow \infty$ , with  $C, F(\cdot)$  bounded independently of  $\varepsilon$ . More precisely, we will be interested in  $S_N$  for which  $F(N) \rightarrow 0$  exponentially or at least at an arbitrarily high algebraic

rate, independently of  $\varepsilon$ . In order to achieve this, information on the asymptotic structure of the solution is necessary.

The asymptotics of the solution  $u$  of (??) were investigated in [?], [?] and are summarized in this section. We begin with the following result from [?].

**Proposition 2.1.** *The solution  $u$  of (??) can be decomposed as  $u = u_{2n} + R_{2n}$ , where  $u_{2n}$  denotes the asymptotic expansion given by*

$$u_{2n} = u_S + u_{BL} + u_C, \quad (2.6)$$

with  $u_S$  the smooth (outer) expansion,  $u_{BL} = V_{2n} + W_{2n} + \bar{V}_{2n} + \bar{W}_{2n}$  the boundary layers along each side of  $\Omega$ , and  $u_C = \sum_{\ell=1}^4 Z_{2n}^\ell$  the corner layers. The remainder  $R_{2n}$  satisfies

$$\|R_{2n}\|_{m,\Omega} \leq C_n \varepsilon^{2n+1-m}, \quad m \leq 2n+1, \quad (2.7)$$

$C_n \in \mathbb{R}$  independent of  $\varepsilon$ .

In (??), the smooth part  $u_S \equiv U_{2n}$  is given by

$$U_{2n}(x, y) = \sum_{i=0}^{2n} \varepsilon^i u_i(x, y)$$

where  $u_0(x, y) = f(x, y)$ ,  $u_i(x, y) = \Delta u_{i-2}(x, y)$ ,  $i \geq 2$  and  $u_i = 0$  for  $i$  odd. That is,

$$U_{2n}(x, y) = \begin{cases} \sum_{i=0}^{2n} \varepsilon^i \Delta^{(i)} f(x, y) & \text{for } i \text{ even} \\ 0 & \text{for } i \text{ odd.} \end{cases} \quad (2.8)$$

The boundary layer  $V_{2n}$  (along the  $x$ -axis) is given by

$$V_{2n}(x, y/\varepsilon) = \sum_{i=0}^{2n} \varepsilon^i v_i(x, y/\varepsilon), \quad (2.9)$$

where, with  $\eta = y/\varepsilon$ ,  $v_i(x, \eta)$  are defined recursively by

$$\begin{aligned} -v_{i,\eta\eta} + v_i &= 0, \quad i = 0, 1, \\ -v_{i,\eta\eta} + v_i &= v_{i-2,xx}, \quad i = 2, \dots, 2n, \end{aligned} \quad (2.10)$$

along with boundary conditions

$$\begin{aligned} v_i(x, 0) &= -u_i(x, 0), \\ v_i(x, \eta) &\rightarrow 0 \text{ as } \eta \rightarrow \infty, \quad i = 0, 1, \dots, 2n. \end{aligned} \quad (2.11)$$

The boundary layers along the other three sides of  $\Omega$  are defined as

$$W_{2n}(\xi, y) = \sum_{i=0}^{2n} \varepsilon^i w_i(\xi, y), \quad \bar{V}_{2n}(x, \bar{\eta}) = \sum_{i=0}^{2n} \varepsilon^i \bar{v}_i(x, \bar{\eta}), \quad \bar{W}_{2n}(\bar{\xi}, y) = \sum_{i=0}^{2n} \varepsilon^i \bar{w}_i(x, \bar{\eta}),$$

where  $\xi = x/\varepsilon$ ,  $\bar{\xi} = (1-x)/\varepsilon$ ,  $\bar{\eta} = (1-y)/\varepsilon$  and  $w_i, \bar{v}_i, \bar{w}_i$  are obtained in a similar way as  $v_i$ . In the next section, we will address the nature of these boundary layers in a more explicit way, in order to define a finite element scheme for their effective approximation.

The corner layers  $Z_{2n}^\ell$ ,  $\ell = 1, \dots, 4$ , in (??) are defined as

$$Z_{2n}^\ell = \sum_{i=0}^{2n} \varepsilon^i z_i^\ell, \quad (2.12)$$

where, for  $\ell = 1$ ,  $z_i^1$  satisfies the following boundary value problem in the stretched variables  $\xi = x/\varepsilon$ ,  $\eta = y/\varepsilon$ :

$$\begin{aligned} -z_{i,\xi\xi}^1 - z_{i,\eta\eta}^1 + z_i^1 &= 0 \text{ in } Q_1 = (0, \infty) \times (0, \infty) \\ z_i^1(\xi, 0) &= -w_i(\xi, 0), \\ z_i^1(0, \eta) &= -v_i(0, \eta), \\ z_i^1(\xi, \eta) &\rightarrow 0 \text{ as } \xi, \eta \rightarrow \infty, \end{aligned} \quad (2.13)$$

for  $i = 0, 1, \dots, 2n$ . Moreover, we have from [?]

$$\begin{aligned} |z_i^1(\xi, \eta)| &\leq C e^{-a\rho}, \quad 0 \leq \xi, \eta \leq \infty, \\ |D_{\xi\eta}^m z_i^1(\xi, \eta)| &\leq C e^{-a\rho}, \quad \rho \geq 1, \end{aligned} \quad (2.14)$$

with  $\rho = (\xi^2 + \eta^2)^{1/2}$  and  $C, a \in \mathbb{R}$  independent of  $\varepsilon$ . The other three corner layers  $Z_{2n}^\ell$ ,  $\ell = 2, 3, 4$  are defined by similar equations to (??) and satisfy similar bounds to (??).

Since by (??) the finite element error is a best approximation error, we design  $S_N \subset H^1(\Omega)$  so that  $u = u_{2n} + R_{2n}$  can be robustly approximated. We will do this separately for each part of the decomposition (??), since

$$\begin{aligned} \inf_{v \in S_N} \|u - v\|_{\varepsilon, \Omega} &\leq \inf_{v_1 \in S_N} \|u_{BL} - v_1\|_{\varepsilon, \Omega} + \inf_{v_2 \in S_N} \|u_C - v_2\|_{\varepsilon, \Omega} + \\ &+ \inf_{v_3 \in S_N} \|u_S - v_3\|_{\varepsilon, \Omega} + \inf_{v_4 \in S_N} \|R_{2n} - v_4\|_{\varepsilon, \Omega}. \end{aligned} \quad (2.15)$$

We will in the following construct specific subspaces  $S_N^{BL}, S_N^C$  for the boundary and corner layer approximation, respectively. We will also construct the space  $S_N^R$  for the approximation of the smooth part and the remainder. The subspace  $S_N$  will then be designed such that  $S_N^{BL} \subset S_N, S_N^C \subset S_N$  and  $S_N^R \subset S_N$ , allowing us to bound (??). Finally, a correction term is subtracted to ensure our approximation to  $u$  is in  $H_0^1(\Omega)$ .

### III. BOUNDARY LAYER APPROXIMATION

We consider the first term in the error bound (??) and, in particular, the design of the finite element space  $S_N^{BL}$  to approximate the boundary layer  $u_{BL}$  in (??). We will present the analysis for the approximation of  $V_{2n}$  and note that the other three boundary layers can be approximated in the same way. Recall that

$$V_{2n} = \sum_{i=0}^{2n} \varepsilon^i v_i(x, y/\varepsilon),$$

with  $v_i$  satisfying (??), (??). It is then easy to see that

$$v_0 = -f(x, 0)e^{-y/\varepsilon}, \quad (3.1)$$

and  $v_i = 0$  for  $i$  odd. In general, using an inductive argument, which appears in the appendix, we have (for  $i > 0$  even)

$$v_i = e^{-y/\varepsilon} \left\{ f^{(i)}(x, 0)\pi_{i/2}(y/\varepsilon) + c_i \Delta^{(i)} f(x, 0) + \sum_{j=1}^{i/2-1} \widehat{\pi}_{i/2-j}(y/\varepsilon) \frac{\partial^{i-2j}}{\partial x^{i-2j}} \left( \Delta^{(2j)} f(x, 0) \right) \right\}, \quad (3.2)$$

where  $\pi_k(y/\varepsilon)$  and  $\widehat{\pi}_k(y/\varepsilon)$  are polynomials of degree  $k$ , and  $c_i \in \mathbb{R}$ . This shows that the boundary layers are sums of products of a ‘‘smooth’’ function and the one-dimensional boundary layer  $\exp(-y/\varepsilon)$ . Using the results of [?], we will construct tensor product spaces (see [?]) for approximating  $V_{2n}$  and, in turn,  $u_{BL}$ .

To this end, let  $\Pi_p(\Omega)$  denote the space of polynomials of degree  $\leq p$  in each variable, and consider the approximation of

$$v(x, y) = C(x)\pi_k(y) e^{-y/\varepsilon} \quad (3.3)$$

by  $\phi(x, y) = \phi_1(x)\phi_2(y) \in \Pi_p(\Omega)$ , where  $\phi_2(y) = \phi_2^1(y)\phi_2^2(y)$  and  $\pi_k(y)$  is a polynomial of degree  $k$  in  $y$ . With  $J = (0, 1)$ , let  $\phi_1(x) \in \Pi_p(J)$  be the  $H^1$  projection of  $C(x)$  onto  $\Pi_p(J)$ , and denote

$$C_i^p := C_i^p(J) = \left\| \frac{d^i}{dx^i} (C(x) - \phi_1(x)) \right\|_{0,J}, \quad i = 0, 1. \quad (3.4)$$

We have the following lemma.

**Lemma 3.1.** *Let  $v(x, y)$  be given by (??) with  $C(x)$  analytic, and for  $\kappa$ , a fixed constant, suppose that  $\kappa p \varepsilon < 1$ . In  $J = (0, 1)$ , use a mesh given by  $\{J_1, J_2, J_3\}$ ,  $J_1 = (0, \kappa p \varepsilon / 2)$ ,  $J_2 = (\kappa p \varepsilon / 2, 1 - \kappa p \varepsilon / 2)$ ,  $J_3 = (1 - \kappa p \varepsilon / 2, 1)$ . Define further on  $\Omega = (0, 1)^2$  the corresponding tensor product mesh*

$$\Delta = \{\Omega_{ij}\}_{1 \leq i, j \leq 3}, \Omega_{ij} = J_i \times J_j, \quad (3.5)$$

with degree vector  $\vec{p} = \{p_{ij}\}_{1 \leq i, j \leq 3}$ ,  $p_{ij} = p > 2k$ , and for  $\Sigma = (\Delta, \vec{p})$  set

$$S_N^{BL}(\Sigma) = \{\psi \in C^0(\Omega) : \psi|_{\Omega_{ij}} \in \Pi_p(\Omega_{ij}), \Omega_i \in \Delta\}. \quad (3.6)$$

Then, there exists  $\phi(x, y) \in S_N^{BL}(\Sigma)$  such that

$$\|v - \phi\|_{\varepsilon, \Omega} \leq K \varepsilon^{1/2} \alpha^p, \quad (3.7)$$

where  $K \in \mathbb{R}$  is independent of  $\varepsilon$  and  $p$ , and  $\alpha < 1$ .

**Proof.** With  $\phi(x, y) = \phi_1(x)\phi_2(y)$  we have

$$\|v(x, y) - \phi(x, y)\|_{\varepsilon, \Omega} = \left\| C(x)\pi_k(y) e^{-y/\varepsilon} - \phi_1(x)\phi_2(y) \right\|_{\varepsilon, \Omega}.$$

A calculation gives

$$\begin{aligned} \|v(x, y) - \phi(x, y)\|_{\varepsilon, \Omega} &\leq K_0 \left\{ \left( \|C(x)\|_{\varepsilon, J} + C_0^p + \varepsilon C_1^p \right) \left\| \pi_k(y) e^{-y/\varepsilon} - \phi_2(y) \right\|_{\varepsilon, J} + \right. \\ &\quad \left. + C_0^p \left\| \pi_k(y) e^{-y/\varepsilon} \right\|_{\varepsilon, J} + \varepsilon C_1^p \left\| \pi_k(y) e^{-y/\varepsilon} \right\|_{0, J} \right\}, \end{aligned} \quad (3.8)$$

with  $K_0 \in \mathbb{R}$  independent of  $\varepsilon$  and  $C_i^p$ ,  $i = 0, 1$  given by (??). Let us concentrate on the term  $\left\| \pi_k(y) e^{-y/\varepsilon} - \phi_2(y) \right\|_{\varepsilon, J}$ . Since  $\phi_2(y) = \phi_2^1(y) \phi_2^2(y)$  with  $\phi_2^i(y) \in \Pi_{p/2}(J)$ ,  $i = 1, 2$ , we have

$$\begin{aligned} \left\| \pi_k(y) e^{-y/\varepsilon} - \phi_2(y) \right\|_{\varepsilon, J} &= \left\| \pi_k(y) e^{-y/\varepsilon} - \pi_k(y) \phi_2^2(y) + \pi_k(y) \phi_2^2(y) + \phi_2^1(y) \phi_2^2(y) \right\|_{\varepsilon, J} \\ &\leq K_1 \left\{ \left\| \pi_k(y) \right\|_{\varepsilon, J} \left\| e^{-y/\varepsilon} - \phi_2^2(y) \right\|_{\varepsilon, J} + \left\| \phi_2^2(y) \right\|_{\varepsilon, J} \left\| \pi_k(y) - \phi_2^1(y) \right\|_{\varepsilon, J} \right\}. \end{aligned}$$

Since  $p > 2k$ , then  $\left\| \pi_k(y) - \phi_2^1(y) \right\|_{\varepsilon, J} = 0$  and

$$\left\| \pi_k(y) e^{-y/\varepsilon} - \phi_2(y) \right\|_{\varepsilon, J} \leq K_1 \left\| \pi_k(y) \right\|_{\varepsilon, J} \left\| e^{-y/\varepsilon} - \phi_2^2(y) \right\|_{\varepsilon, J}. \quad (3.9)$$

Let  $t = 2y - 1$ . Then,

$$\left\| e^{-y/\varepsilon} - \phi_2^2(y) \right\|_{\varepsilon, J} = \left\| e^{-(t+1)/2\varepsilon} - \phi_2^2\left(\frac{t+1}{2}\right) \right\|_{\varepsilon, (-1, 1)} = \left\| e^{-(t+1)/2\varepsilon} - \tilde{\phi}_2^2 \right\|_{\varepsilon, (-1, 1)}.$$

By Theorem 5.1 of [?], there exists  $\tilde{\phi}_2^2$  such that

$$\left\| e^{-(t+1)/2\varepsilon} - \tilde{\phi}_2^2 \right\|_{\varepsilon, (-1, 1)} \leq K_2 \varepsilon^{1/2} \tilde{\alpha}^{p+1/2}, \quad (3.10)$$

with  $K_2 \in \mathbb{R}$  independent of  $\varepsilon$  and  $p$ , and  $\tilde{\alpha} < 1$ . Thus, by (??) and (??) we have

$$\left\| \pi_k(y) e^{-y/\varepsilon} - \phi_2(y) \right\|_{\varepsilon, J} \leq K_3 \varepsilon^{1/2} \tilde{\alpha}^{p+1/2}, \quad (3.11)$$

$K_3 \in \mathbb{R}$  independent of  $\varepsilon$  and  $p$ . Finally, since  $C(x)$  was assumed to be analytic, we have from [?]

$$\|C(x)\|_{\varepsilon, J} \leq K_4 \in \mathbb{R}, C_i^p \leq K_5 \beta^p, i = 0, 1$$

with  $0 < \beta < 1$ ,  $\beta, K_5 \in \mathbb{R}$ . Also,  $\left\| \pi_k(y) e^{-y/\varepsilon} \right\|_{\varepsilon, J} \leq 1$  and by (??), (??) we obtain

$$\|v(x, y) - \phi(x, y)\|_{\varepsilon, \Omega} \leq K_6 \beta^p \varepsilon^{1/2} \tilde{\alpha}^{p+1/2} =: K \varepsilon^{1/2} \alpha^p. \quad (3.12)$$

This completes the proof.  $\blacksquare$

As the above lemma shows, approximating functions of type (??) amounts to approximating the one-dimensional boundary layer function  $\exp(-y/\varepsilon)$ . Using the results of [?], this can be done at an exponential rate of convergence. Using Lemma ?? for the approximation of  $V_{2n}$ , we have the following result.

**Lemma 3.2.** *Let  $S_N^{BL}(\Sigma)$  be the space defined in Lemma ???. Then, there exists  $\phi \in S_N^{BL}$  such that*

$$\|V_{2n} - \phi\|_{\varepsilon, \Omega} \leq K \varepsilon^{1/2} \alpha^p,$$

where  $K \in \mathbb{R}$  is independent of  $\varepsilon$  and  $p$ , and  $\alpha < 1$ .

**Proof.** We write  $\phi(x, y) \in S_N^{BL}$  as

$$\phi(x, y) = \sum_{i=0}^{2n} \left( \varphi_i^1(x) \varphi_i^2(y) + \psi_i^1(x) \psi_i^2(y) + \sum_{j=0}^{i/2-1} \chi_j^1(x) \chi_j^2(y) \right).$$

Then, with  $V_{2n}$  given by (??),

$$\begin{aligned} \|V_{2n} - \phi\|_{\varepsilon, \Omega} \leq & \sum_{i=0}^{2n} \left\{ \left\| \varepsilon^i f^{(i)}(x, 0) \pi_{i/2-1}(y/\varepsilon) e^{-y/\varepsilon} - \varphi_i^1(x) \varphi_i^2(y) \right\|_{\varepsilon, \Omega} + \right. \\ & \left. + \left\| \varepsilon^i c_i \Delta^{(i)} f(x, 0) e^{-y/\varepsilon} - \psi_i^1(x) \psi_i^2(y) \right\|_{\varepsilon, \Omega} + \right. \\ & \left. + \sum_{j=0}^{i/2-1} \left\| \varepsilon^i \frac{\partial^{i-2j}}{\partial x^{i-2j}} \left( \Delta^{(2j)} f(x, 0) \right) \pi_{i/2-j}(y/\varepsilon) e^{-y/\varepsilon} - \chi_j^1(x) \chi_j^2(y) \right\|_{\varepsilon, \Omega} \right\}. \end{aligned}$$

Applying Lemma ?? to each term above, gives the lemma.  $\blacksquare$

The mesh for the boundary layer approximation is shown in Fig. ??.

Using the same argument for the approximation of the boundary layers  $W_{2n}, \bar{V}_{2n}, \bar{W}_{2n}$  along the other three sides of  $\Omega$ , we immediately obtain the following theorem.

**Theorem 3.1.** Let  $S_N^{BL}(\Sigma)$  be given by (??) with  $\Sigma = (\Delta, \vec{p})$  given by (??), and let  $u_{BL}$  correspond to the boundary layers in the expansion (??). Then, there exists  $v_1 \in S_N^{BL}(\Sigma)$  such that

$$\|u_{BL} - v_1\|_{\varepsilon, \Omega} \leq K \varepsilon^{1/2} \alpha^p,$$

where  $K \in \mathbb{R}$  is independent of  $\varepsilon$  and  $p$ , and  $\alpha < 1$ .

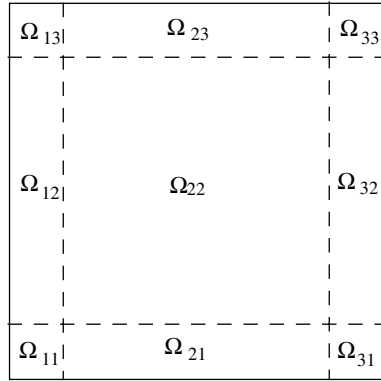

FIG. 1. Partition of  $\Omega$  for boundary layer approximation.

## IV. CORNER LAYER APPROXIMATION

We now turn our attention to the approximation of the corner layers. We will use the following lemma, which follows by a change of variables argument.

**Lemma 4.1.** *Under the stretched variables transformation  $\xi = \frac{x}{\varepsilon}, \eta = \frac{y}{\varepsilon}$ , we have for any function  $v$ , the following correspondence:*

$$\|v(x, y)\|_{\varepsilon, m, I} = \varepsilon \|\tilde{v}(\xi, \eta)\|_{m, \tilde{I}},$$

where

$$\|v\|_{\varepsilon, m, I}^2 := \sum_{i=0}^m \varepsilon^{2i} |v|_{i, I}^2,$$

$\tilde{v}(\xi, \eta) = v(\varepsilon\xi, \varepsilon\eta)$ , and  $\tilde{I} \subseteq Q_1$  denotes the image of any subset  $I \subseteq \Omega$ , under this transformation. For  $m = 1$ ,  $\|\cdot\|_{\varepsilon, m, I}$  coincides with the energy norm and we have

$$\|v(x, y)\|_{\varepsilon, I} = \varepsilon \|\tilde{v}(\xi, \eta)\|_{1, \tilde{I}}.$$

In the subsections that follow, we will design the finite element space  $S_N^C$ , to approximate the corner layers  $u_C$ . This will be done in several steps. First, we will show that each  $Z_{2n}^\ell$ ,  $\ell = 1, \dots, 4$ , is negligible outside the four regions of size  $O(p\varepsilon)$  near the four corners of  $\Omega$ . To this end, let

$$C_\varepsilon^1 = \left\{ (r, \theta) : 0 \leq r \leq \kappa p \varepsilon, 0 \leq \theta \leq \frac{\pi}{2} \right\} \quad (4.1)$$

describe a sector of  $\Omega$  near the corner at the origin and assume  $\varepsilon < \kappa p \varepsilon < 1/2$ . We have the following lemma.

**Lemma 4.2.** *Let  $u_C$  be the corner layer functions in the asymptotic expansion (??) and assume that  $\varepsilon < \kappa p \varepsilon < 1/2$ . Then, for  $\Omega^C := \Omega \setminus \left\{ \bigcup_{i=1}^4 C_\varepsilon^i \right\}$ , we have for  $m \geq 0$ ,  $\ell = 1, \dots, 4$*

$$\|Z_{2n}^\ell\|_{m, \Omega^C}, \|u_C\|_{m, \Omega^C} \leq K(m, n) \varepsilon^{1-m} e^{-b\kappa p}, \quad (4.2)$$

with  $K(m, n), b \in \mathbb{R}$  independent of  $\varepsilon$ .

**Proof.** By the triangle inequality, we get

$$\|u_C\|_{m, \Omega^C} = \left\| \sum_{\ell=1}^4 Z_{2n}^\ell \right\|_{m, \Omega^C} \leq \sum_{\ell=1}^4 \|Z_{2n}^\ell\|_{m, \Omega^C} \leq \sum_{\ell=1}^4 \sum_{i=0}^{2n} \varepsilon^i \|z_i^\ell\|_{m, \Omega^C}.$$

We will concentrate only on  $Z_{2n}^1 := \tilde{Z}(\xi, \eta)$ , so that using Lemma ??, with  $v = Z_{2n}^1, \tilde{v} = \tilde{Z}$ , we get

$$\|Z_{2n}^1\|_{\varepsilon, m, \Omega^C} = \varepsilon \|\tilde{Z}\|_{m, \tilde{\Omega}^C} \leq \varepsilon \|\tilde{Z}\|_{m, Q_1 \setminus C_1^1},$$

where  $C_1^1$  is given by (??) for  $\varepsilon = 1$  and  $Q_1 = (0, \infty) \times (0, \infty)$ . Let us estimate the right-hand side of the above inequality. We have

$$\|\tilde{Z}\|_{m, Q_1 \setminus C_1^1}^2 \leq \sum_{i=0}^{2n} \varepsilon^i \|z_i^1\|_{m, \Omega^C}^2 \leq \sum_{i=0}^{2n} \varepsilon^i \sum_{|\alpha| \leq m} \left\{ \int \int_{Q_1 \setminus C_1^1} |D^\alpha \tilde{Z}|^2 d\xi d\eta \right\}.$$

We introduce polar coordinates  $(\rho, \theta)$ , and, since  $1 < \kappa p \leq \rho$ , we can use (??) to bound the quantity in the integral. We obtain

$$\begin{aligned} \|\tilde{Z}\|_{m, Q_1 \setminus C_1^1}^2 &\leq \sum_{i=0}^{2n} \varepsilon^i \sum_{|\alpha| \leq m} (C_m)^2 \int_{\kappa p}^{\infty} \int_0^{\pi/2} \{e^{-2b\rho}\} \rho d\theta d\rho \\ &\leq \sum_{i=0}^{2n} \varepsilon^i C(m, b, \kappa) p e^{-2b\kappa p} \leq C p e^{-2b\kappa p} \end{aligned} \quad (4.3)$$

with  $C \in \mathbb{R}$  independent of  $\varepsilon$ , but depending on  $n, m, b$ , and  $\kappa$ . Thus,  $\|Z_{2n}^1\|_{\varepsilon, m, \Omega^C} \leq \varepsilon C p e^{-b\kappa p}$  with  $b \in \mathbb{R}$  as in (??). By definition,

$$\|Z_{2n}^1\|_{\varepsilon, m, \Omega^C}^2 = \sum_{i=0}^m \varepsilon^{2i} |Z_{2n}^1|_{i, \Omega^C}^2 \geq \varepsilon^{2m} \|Z_{2n}^1\|_{m, \Omega^C}^2,$$

so that

$$\|Z_{2n}^1\|_{m, \Omega^C} \leq \varepsilon^{-m} \|Z_{2n}^1\|_{\varepsilon, m, \Omega^C} \leq C \varepsilon^{1-m} p e^{-b\kappa p}.$$

A similar argument can be used for the other three corner layers to obtain

$$\|Z_{2n}^\ell\|_{m, \Omega^C} \leq C \varepsilon^{1-m} p e^{-b\kappa p}, \ell = 1, \dots, 4.$$

Then (??) follows by adjusting the values of the constants. ■

Using Lemma ??, we see that  $\|u_C\|_{\varepsilon, \Omega^C} \leq C \varepsilon e^{-b\kappa p}$  which is small. Hence  $u_C$  need only be “well” approximated to a distance of  $O(p\varepsilon)$  near each corner. This will be taken into consideration in the design of the finite element space. We will consider only the approximation of  $Z_{2n}^1 = \tilde{Z}(\xi, \eta)$  from this point forward.

The approximation of  $\tilde{Z}$  in  $(0, \kappa p)^2$  will consist of two parts: first over a fixed region  $\tilde{I} = (0, \kappa)^2$ , and then over the remaining portion of  $(0, \kappa p)^2$ . This will be done in Sections IV.A and IV.B. In Section IV.C, the approximation over the entire domain  $\Omega$  is presented. To this end, let  $\Omega_1 := (0, \kappa p \varepsilon) \times (0, \kappa p \varepsilon)$  and subdivide it into two regions  $I$  and  $II$  as follows:

$$\begin{aligned} I &= (0, \kappa \varepsilon) \times (0, \kappa \varepsilon), \\ II &= \Omega_1 \setminus I. \end{aligned}$$

(See Fig. ??).

### A. Approximation over $(0, \kappa \varepsilon)^2$

Let us first focus on region  $I$ . Let  $\xi = \frac{x}{\varepsilon}, \eta = \frac{y}{\varepsilon}$  denote stretched variables, as before, and note the following.

- Region  $I = (0, \kappa \varepsilon)^2$  in the  $x - y$  plane is transformed into  $\tilde{I} = (0, \kappa)^2$  in the  $\xi - \eta$  plane.
- $\|Z_{2n}^1\|_{\varepsilon, I} = \varepsilon \|\tilde{Z}(\xi, \eta)\|_{1, \tilde{I}}$ .

Let us briefly address the regularity of  $\tilde{Z}$ . Recall that  $\tilde{Z}$  is given as a sum of terms  $z_{2n}^1$  satisfying (??) where the boundary data is analytic. Thus, no singularities occur, except possibly at the origin. It can be shown (using Theorem 3.1 of [?]), that the restriction of the solution  $z_{2n}^1$  of (??) to  $\tilde{I} = (0, \kappa)^2$ , belongs to the *countably normed* space  $B_\beta^2(\tilde{I})$ , defined in [?]. Hence,  $\tilde{Z} \in B_\beta^2(\tilde{I})$ .

To obtain a finite element approximation of the corner layer  $\tilde{Z}$  in  $\tilde{I}$ , define a *geometric mesh*,  $\tilde{I}_\sigma^n$  with geometric ratio  $\sigma$ ,  $0 < \sigma < 1$ , and number of layers  $n + 1 \geq 2$  on  $\tilde{I}$  (i.e., in stretched coordinates) as follows. Let  $\xi_0 = \eta_0 = 0$ ,  $\xi_j = \eta_j = \sigma^{n+1-j}$ ,  $1 \leq j \leq n + 1$  and

$$\begin{aligned}\tilde{I}_{1,j} &= (\xi_{j-1}, \xi_j) \times (\eta_{j-1}, \eta_j) \text{ for } 1 \leq j \leq n + 1, \\ \tilde{I}_{2,j} &= (\xi_{j-1}, \xi_j) \times (0, \eta_{j-1}) \text{ for } 2 \leq j \leq n + 1, \\ \tilde{I}_{3,j} &= (0, \xi_{j-1}) \times (\eta_{j-1}, \eta_j) \text{ for } 2 \leq j \leq n + 1.\end{aligned}$$

Further divide each  $\tilde{I}_{i,j}$ ,  $i, j \geq 2$ , into three triangles  $\tilde{I}_{i,j}^k$ ,  $i \leq k \leq 3$  and define the mesh

$$\tilde{I}_\sigma^n = \left\{ \begin{array}{l} \tilde{I}_{i,j}, \text{ for } i = 1, 1 \leq j \leq n + 1, 2 \leq i \leq 3, j = 2 \text{ and} \\ \tilde{I}_{i,j}^k \text{ for } 1 \leq k \leq 3, 2 \leq i \leq 3, 2 \leq j \leq n + 1 \end{array} \right\}. \quad (4.4)$$

An example of such a *geometric mesh* is illustrated in Fig. ??.

Define the space

$$S^p(\tilde{I}_\sigma^n) = \left\{ \begin{array}{l} u \in H^1(\Omega) : u|_{\tilde{I}_{i,j}^k} \in \Pi_p(\tilde{I}_{i,j}^k), 1 \leq k \leq 3, 2 \leq i \leq 3, 2 \leq j \leq n + 1 \\ u|_{\tilde{I}_{i,j}} \in \Pi_p(\tilde{I}_{i,j}) \text{ for } i = 1, 1 \leq j \leq n + 1, \text{ or } 1 \leq i \leq 3, j = 2 \end{array} \right\}. \quad (4.5)$$

Also,  $S^p(I_\sigma^n)$  is the space defined on a geometric mesh over  $(0, \kappa\varepsilon)^2$ , analogously to (??). We have the following result from [?].

**Proposition 4.1.** *Let  $\tilde{I} = (0, \kappa) \times (0, \kappa)$  and let  $\tilde{I}_\sigma^n$  be the geometric mesh (??) with  $n = O(p)$ . If  $u \in B_\beta^2(\tilde{I})$  with  $0 < \beta < 1$ , then for any  $0 < \sigma < 1$  there exists a piecewise polynomial  $\psi(\xi, \eta) \in S^p(\tilde{I}_\sigma^n)$  such that*

$$\|u - \psi\|_{1, \tilde{I}} \leq C e^{-a_1 N^{1/3}}, \quad (4.6)$$

where  $N$  is the number of degrees of freedom of the space  $S^p(\tilde{I}_\sigma^n)$ , and  $a_1, C \in \mathbb{R}$  are independent of  $p, \varepsilon$ , and  $N$ .

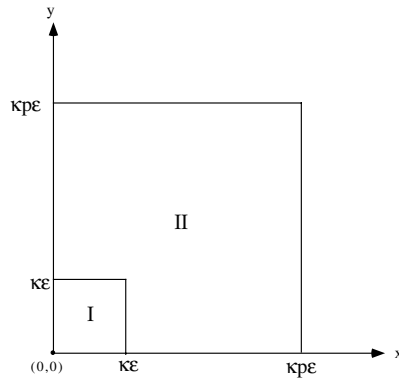

FIG. 2. Definition of regions I and II.

Using Proposition 4.1 we have the following result for the approximation of the corner layer.

**Lemma 4.3.** *Let  $Z_{2n}^1$  be the corner layer at the origin, and let  $S^p(I_\sigma^n)$  be the space defined analogously to  $S^p(\tilde{I}_\sigma^n)$  by (??). Then there exists  $\psi \in S^p(I_\sigma^n)$  such that*

$$\|Z_{2n}^1 - \psi\|_{\varepsilon, I} \leq C\varepsilon e^{-a_1 N^{1/3}}, \quad (4.7)$$

with  $C, a_1 \in \mathbb{R}$  independent of  $\varepsilon$ , and  $N = \dim(S^p(I_\sigma^n))$ .

**Proof.** By Lemma ??,  $\|Z_{2n}^1 - \psi\|_{\varepsilon, I} = \varepsilon \|\tilde{Z} - \tilde{\psi}\|_{1, \tilde{I}}$ , where  $\tilde{\psi} = \psi(\varepsilon\xi, \varepsilon\eta)$ . Moreover, since  $\tilde{Z}(\xi, \eta)$  belongs to the countably normed space  $B_\beta^2(\tilde{I})$ , we can use Proposition 4.1 with  $u = \tilde{Z}$ , to obtain

$$\|\tilde{Z} - \tilde{\psi}\|_{1, \tilde{I}} \leq C e^{-a_1 N^{1/3}},$$

where  $\tilde{\psi}(\xi, \eta) \in S^p(\tilde{I}_\sigma^n)$ . Combining the two, we obtain the result.  $\blacksquare$

**Remark 4.1.** *The estimate (??), in Lemma ??, holds for the other corner layer functions  $Z_{2n}^\ell$ ,  $\ell = 2, 3, 4$ , as well, with  $S^p(I_\sigma^n)$  replaced by the analogous spaces defined in the corresponding regions  $I^2 = (1 - \kappa\varepsilon, 1) \times (0, \kappa\varepsilon)$ ,  $I^3 = (1 - \kappa\varepsilon, 1) \times (1 - \kappa\varepsilon, 1)$ ,  $I^4 = (0, \kappa\varepsilon) \times (1 - \kappa\varepsilon, 1)$ .*

## B. Approximation over $(0, \kappa p\varepsilon)^2 \setminus (0, \kappa\varepsilon)^2$

Let us now turn our attention to the finite element approximation of the corner layer in the transitional region  $II$ . Our goal is, as before, to define a finite element space  $S^p(II)$  in order to approximate the corner layer over region  $II$ . Using stretched variables, we map region  $II = (0, \kappa p\varepsilon)^2 \setminus (0, \kappa\varepsilon)^2$ , from the  $x-y$  plane to  $\tilde{II} = (0, \kappa p)^2 \setminus (0, \kappa)^2$  in the  $\xi-\eta$  plane. Further (see

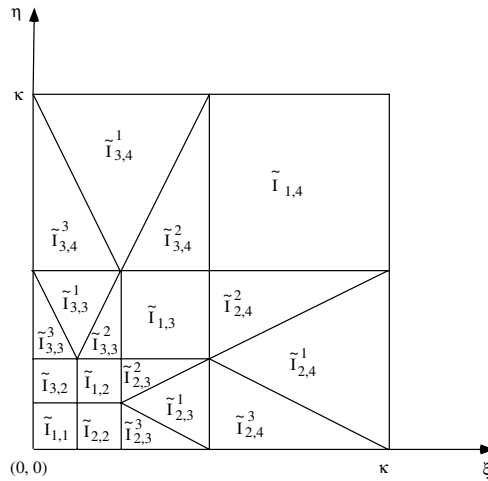

FIG. 3. The geometric mesh on region  $\tilde{I}$  with  $\sigma = 1/2$  and  $n = 3$ .



and note that it consists only of rectangular elements.  $(\widetilde{II}_{\sigma,*}^{-\nu(p)})$  is *not* regular in the sense of [?]. We begin the construction of an approximation to  $\widetilde{Z}(\xi, \eta)$  in region  $\widetilde{II}^-$ , first on the rectangulation  $\widetilde{II}_{\sigma,*}^{-\nu(p)}$  defined above. We have the following result.

**Lemma 4.4.** [?] *Let  $\widetilde{Z}(\xi, \eta)$  correspond to the corner layer at the origin. Then, with*

$$S^p \left( \widetilde{II}_{\sigma,*}^{-\nu(p)} \right) = \left\{ u : u|_{\widetilde{II}_{i,j}^-} \in \Pi_p \left( \widetilde{II}_{i,j}^- \right) \text{ for } 1 \leq i \leq 3, 1 \leq j \leq \nu(p) \right\}, \quad (4.9)$$

there exists  $\widetilde{\phi}(\xi, \eta) \in S^p \left( \widetilde{II}_{\sigma,*}^{-\nu(p)} \right)$  such that  $\widetilde{\phi} = \widetilde{Z}$  at each node of  $\widetilde{II}_{\sigma,*}^{-\nu(p)}$ , and

$$\sum_{i=1}^3 \sum_{j=1}^{\nu(p)} \left\| D^m \left( \widetilde{Z} - \widetilde{\phi} \right) \right\|_{0, \widetilde{II}_{i,j}^-}^2 \leq C(\kappa, \sigma, m, s) p^{-2s-2+2m}, \quad m = 0, 1, 2, \quad (4.10)$$

for any integer  $s > 0$ .

**Proof.** See proof of Lemma 4.3.6 in [?]. ■

Next, we consider the values of the corner layers and the approximating polynomials at the *irregular* nodes. We define an *irregular* node to be a vertex of an element that lies in the interior of a side of an adjacent element. Other nodes are termed regular. Note that, even though  $\widetilde{\phi}$  and  $\widetilde{Z}$  agree at each regular node of the rectangulation  $\widetilde{II}_{\sigma,*}^{-\nu(p)}$ , we need to adjust the inter-element jumps in the approximating polynomials  $\widetilde{\phi}(\xi, \eta)$  at each irregular node. This is done analogously to the technique in [?] and the details can be found in the proof of Lemma 4.3.7 in [?]. To this end, further divide each  $\widetilde{II}_{i,j}^-$ ,  $i \geq 2$ , into three triangles  $\widetilde{II}_{i,j}^{-k}$ ,  $1 \leq k \leq 3$ , and define the mesh

$$\widetilde{II}_{\sigma}^{-\nu(p)} = \left\{ \begin{array}{l} \widetilde{II}_{i,j}^-, \text{ for } i = 1, 1 \leq j \leq \nu(p), \text{ and} \\ \widetilde{II}_{i,j}^{-k} \text{ for } 1 \leq k \leq 3, 2 \leq i \leq 3, 1 \leq j \leq \nu(p) \end{array} \right\}. \quad (4.11)$$

This mesh is similar to the geometric mesh defined for region  $I$  by (??). Note that  $\widetilde{II}_{\sigma}^{-\nu(p)}$  is defined in the  $\xi - \eta$  plane. We could obtain a mesh,  $II_{\sigma}^{-\nu(p)}$ , over region  $II$  in the  $x - y$  plane, by using the stretched variable transformation. Figure ?? illustrates the mesh  $\widetilde{II}_{\sigma}^{-\nu(p)}$ .

**Lemma 4.5.** [?] *Let  $\widetilde{Z}(\xi, \eta)$  correspond to the corner layer at the origin and define the space*

$$S^p \left( \widetilde{II}_{\sigma}^{-\nu(p)} \right) = \left\{ \begin{array}{l} u \in H^1(\Omega) : u|_{\widetilde{II}_{i,j}^-} \in \Pi_p \left( \widetilde{II}_{i,j}^- \right), i = 1, 1 \leq j \leq \nu(p), \\ u|_{\widetilde{II}_{i,j}^{-k}} \in \Pi_p \left( \widetilde{II}_{i,j}^{-k} \right), 1 \leq k \leq 3, 2 \leq i \leq 3, 1 \leq j \leq \nu(p), \end{array} \right\}. \quad (4.12)$$

Then, there exists  $\widetilde{\psi}(\xi, \eta) \in S^p \left( \widetilde{II}_{\sigma}^{-\nu(p)} \right)$  such that  $\widetilde{\psi} = \widetilde{Z}$  at each node of  $\widetilde{II}_{\sigma}^{-\nu(p)}$ , and

$$\left\| \widetilde{Z} - \widetilde{\psi} \right\|_{1, \widetilde{II}^-}^2 \leq C(\kappa, \sigma, s) p^{-2s+2}, \quad (4.13)$$

for any integer  $s > 0$ .

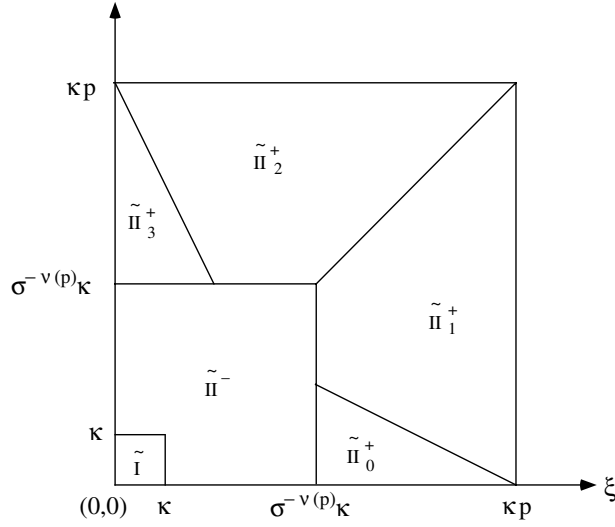

FIG. 5. The mesh on region  $\widetilde{II}^+$ .

**Proof.** See proof of Lemma 4.3.7 in [?]. ■

As a final step in the construction of the corner layer approximation, we would like to set the approximating polynomial  $\widetilde{\psi}(\xi, \eta) \in S^p \left( \widetilde{II}_\sigma^{-\nu(p)} \right)$ , to zero along the outer boundary of region  $\widetilde{II}^+ = (0, \kappa p)^2 \setminus (0, \sigma^{-\nu(p)} \kappa)^2$ , which we partition into  $\widetilde{II}_*^+ = \{ \widetilde{II}_i^+, i = 0, \dots, 3 \}$  as shown in Fig. ??, again without reducing the order of approximation. The result is given in the following lemma.

**Lemma 4.6.** [?] Let  $\widetilde{Z}(\xi, \eta)$  correspond to the corner layer at the origin, and define the space

$$S^p \left( \widetilde{II}_*^+ \right) = \left\{ u \in H^1(\Omega) : u|_{\widetilde{II}_i^+} \in \Pi_p \left( \widetilde{II}_i^+ \right), i = 0, \dots, 3 \right\}. \quad (4.14)$$

Then, there exists  $\widetilde{\psi}(\xi, \eta) \in S^p \left( \widetilde{II}_*^+ \right)$  such that  $\widetilde{\psi}(\kappa p, \eta) = \widetilde{\psi}(\xi, \kappa p) = 0$ , and

$$\left\| \widetilde{Z} - \widetilde{\psi} \right\|_{1, \widetilde{II}^+}^2 \leq C(\kappa, \sigma, s) p^{-2s+2}, \quad (4.15)$$

for any integer  $s$ .

**Proof.** See proof of Lemma 4.3.8 in [?]. ■

Lemmas ?? and ?? give us the necessary tools for approximating  $\widetilde{Z}$  over regions  $\widetilde{II}^-$  and  $\widetilde{II}^+$ , respectively. Since  $\widetilde{Z}$  corresponds to the corner layer at the origin, we have the following immediate result.

**Theorem 4.1.** Let  $Z_{2n}^1$  be the corner layer at the origin, and let  $II_\sigma^{\nu(p)} = \{II_\sigma^{-\nu(p)} \cup II_*^+\}$  denote the union of the meshes over regions  $II^-$  and  $II^+$ . Define the space

$$S^p \left( II_\sigma^{\nu(p)} \right) = \left\{ \begin{array}{l} v \in H^1(\Omega) : v \in S^p \left( II_\sigma^{-\nu(p)} \right) \text{ over region } II^- \\ v \in S^p \left( II_*^+ \right) \text{ over region } II^+ \end{array} \right\}, \quad (4.16)$$

where  $S^p \left( II_\sigma^{-\nu(p)} \right)$  and  $S^p \left( II_*^+ \right)$  are spaces defined analogously to (??), (??). Then, for any integer  $s > 0$ , there exists  $\phi^1 \in S^p \left( II_\sigma^{\nu(p)} \right)$  such that  $\phi^1 = Z_{2n}^1$  at each vertex of  $II_\sigma^{-\nu(p)}$ ,  $\phi^1 = 0$  on the outer boundary of region  $II^+$ , and

$$\|Z_{2n}^1 - \phi^1\|_{\varepsilon, II} \leq \varepsilon C(\kappa, \sigma, s) p^{-s}, \quad (4.17)$$

where  $C \in \mathbb{R}$  is independent of  $p$  and  $\varepsilon$ , but depends on  $\kappa, \sigma$ , and  $s$ .

**Proof.** Using Lemma ??,

$$\|Z_{2n}^1 - \phi^1\|_{\varepsilon, II} = \varepsilon \|\tilde{Z} - \tilde{\phi}^1\|_{1, \tilde{II}} = \varepsilon \left( \|\tilde{Z} - \tilde{\phi}^1\|_{1, \tilde{II}^-} + \|\tilde{Z} - \tilde{\phi}^1\|_{1, \tilde{II}^+} \right),$$

where  $\tilde{\phi}^1 = \phi^1(\varepsilon\xi, \varepsilon\eta)$ . Applying Lemmas ?? and ??, we obtain (??). ■

### C. Approximation over $\Omega$

With Theorem 4.1 we have an estimate for the corner layer function  $Z_{2n}^1$  in a region of size  $O(p\varepsilon)$  near the origin. The same estimate can be established in a similar fashion for the other three corner layers  $Z_{2n}^\ell, \ell = 2, \dots, 4$ . This, together with the fact that  $Z_{2n}^\ell, \ell = 1, \dots, 4$ , are “small” away from each corner (as Lemma ?? shows), gives us a tool for approximating  $u_C$  over the entire domain  $\Omega$ . Moreover, the space  $S_N^{BL}$  defined by (??), used in the approximation of the boundary layer part  $u_{BL}$ , satisfies

$$S_N^{BL} \subset S_N^C, \quad (4.18)$$

where  $S_N^C$  is defined by (??) below, as the space used in approximating  $u_C$ . Therefore, if  $S_N^C$  is used instead of  $S_N^{BL}$ , in the  $O(p\varepsilon)$  region near each corner, the estimate (??) will still hold.

To close our discussion on the corner layers, let  $\Omega_{\sigma, \nu(p)}^1 = \{I_\sigma^{\nu(p)}, II_\sigma^{\nu(p)}\}$  be the geometric mesh over  $(0, \kappa p\varepsilon) \times (0, \kappa p\varepsilon) \subset \Omega$ , and similarly let  $\Omega_{\sigma, \nu(p)}^i, i = 2, 3, 4$  be the corresponding geometric meshes over the regions of size  $(\kappa p\varepsilon)^2$  at the other three corners of  $\Omega$ . Also, let  $\Omega_0^0 = (\kappa p\varepsilon, 1 - \kappa p\varepsilon) \times (\kappa p\varepsilon, 1 - \kappa p\varepsilon)$ ,  $\Omega_1^0 = (\kappa p\varepsilon, 1 - \kappa p\varepsilon) \times (0, \kappa p\varepsilon)$ ,  $\Omega_2^0 = (1 - \kappa p\varepsilon, 1) \times (\kappa p\varepsilon, 1 - \kappa p\varepsilon)$ ,  $\Omega_3^0 = (\kappa p\varepsilon, 1 - \kappa p\varepsilon) \times (1 - \kappa p\varepsilon, 1)$  and  $\Omega_4^0 = (0, \kappa p\varepsilon) \times (\kappa p\varepsilon, 1 - \kappa p\varepsilon)$ . Define the mesh-degree combination  $\Sigma = \left( \Delta, \vec{p} \right)$ , where

$$\Delta = \Omega_0^0 \cup \left\{ \Omega_{\sigma, \nu(p)}^i, \Omega_i^0 \right\}_{i=1}^4, \quad (4.19)$$

and the polynomial degree is  $p > 2n$  for each element, except  $\Omega_i^0, i = 0, \dots, 4$ , where it is zero. We then have the following theorem.

**Theorem 4.2.** Let  $u_C$  be the corner layer in the expansion (??) and define the space

$$S_N^C(\Sigma) = \left\{ v \in H^1(\Omega) : v|_{\Omega_{\sigma, \nu(p)}^i} \in \Pi_p \left( \Omega_{\sigma, \nu(p)}^i \right), v|_{\Omega_i^0} = 0, i = 1, \dots, 4 \right\}, \quad (4.20)$$

with  $\Sigma = (\Delta, \vec{p})$  as in (??), and  $\varepsilon < \kappa p \varepsilon < 1/2$ . Then, for any integer  $s$ , there exists  $\phi \in S_N^C$  such that

$$\|u_C - \phi\|_{\varepsilon, \Omega} \leq C\varepsilon p^{-s}, \quad (4.21)$$

where  $C \in \mathbb{R}$  is independent of  $\varepsilon$  and  $p$ , but depends on  $\kappa, \sigma$ , and  $s$ .

**Proof.** We have  $u_C = \sum_{\ell=1}^4 Z_{2n}^\ell$ , so that

$$\|u_C - \phi\|_{\varepsilon, \Omega} = \left\| \sum_{\ell=1}^4 Z_{2n}^\ell - \phi^\ell \right\|_{\varepsilon, \Omega} \leq \sum_{\ell=1}^4 \|Z_{2n}^\ell - \phi^\ell\|_{\varepsilon, \Omega}, \quad (4.22)$$

where  $\phi = \sum_{\ell=1}^4 \phi^\ell$ , with  $\phi^\ell \in S_N^C(\Sigma)$ . Let us consider the case  $\ell = 1$ . We have for  $\Omega_1 = (0, \kappa p \varepsilon)^2$ ,

$$\begin{aligned} \|Z_{2n}^1 - \phi^1\|_{\varepsilon, \Omega} &= \|Z_{2n}^1 - \phi^1\|_{\varepsilon, \Omega_1} + \|Z_{2n}^1 - \phi^1\|_{\varepsilon, \Omega \setminus \Omega_1} \\ &= \|Z_{2n}^1 - \phi^1\|_{\varepsilon, I} + \|Z_{2n}^1 - \phi^1\|_{\varepsilon, II} + \|Z_{2n}^1 - \phi^1\|_{\varepsilon, \Omega \setminus \Omega_1}. \end{aligned}$$

By Lemma ??, we have

$$\|Z_{2n}^1 - \phi^1\|_{\varepsilon, I} \leq C\varepsilon e^{-aN^{1/3}} = C\varepsilon e^{-a(p^3)^{1/3}} = C\varepsilon e^{-ap}, \quad (4.23)$$

and by Theorem 4.1,

$$\|Z_{2n}^1 - \phi^1\|_{\varepsilon, II} \leq \varepsilon C(b, \kappa, \sigma, m, s) p^{-s}. \quad (4.24)$$

Moreover, since  $\phi^1 = 0$  in  $\Omega \setminus \Omega_1$  we have  $\|Z_{2n}^1 - \phi^1\|_{\varepsilon, \Omega \setminus \Omega_1} = \|Z_{2n}^1\|_{\varepsilon, \Omega \setminus \Omega_1}$  and by Lemma ??

$$\|Z_{2n}^1\|_{\varepsilon, \Omega \setminus \Omega_1} \approx \varepsilon \|Z_{2n}^1|_{1, \Omega \setminus \Omega_1}\| + \|Z_{2n}^1\|_{0, \Omega \setminus \Omega_1} \leq K_1 \varepsilon e^{-b\kappa p},$$

with  $K_1 \in \mathbb{R}$  independent of  $\varepsilon$  and  $p$ . Thus,

$$\|Z_{2n}^1 - \phi^1\|_{\varepsilon, \Omega \setminus \Omega_1} \leq K_1 \varepsilon e^{-b\kappa p}. \quad (4.25)$$

Combining (??), (??), and (??), we obtain

$$\|Z_{2n}^1 - \phi^1\|_{\varepsilon, \Omega} \leq C\varepsilon e^{-ap} + \varepsilon C(\kappa, \sigma, s) p^{-s} + K_1 \varepsilon e^{-b\kappa p} \leq \varepsilon \tilde{C} p^{-s} \quad (4.26)$$

with  $\tilde{C} \in \mathbb{R}$  independent of  $\varepsilon$  and  $p$ , but depending on  $\kappa, \sigma, s$ , and  $a$ . The same estimate holds for  $Z_{2n}^\ell, \ell = 2, \dots, 4$ , so that (??) gives

$$\|u_C - \phi\|_{\varepsilon, \Omega} \leq \sum_{\ell=1}^4 \|Z_{2n}^\ell - \phi^\ell\|_{\varepsilon, \Omega} \leq \sum_{\ell=1}^4 \varepsilon \tilde{C} p^{-s} \leq C\varepsilon p^{-s},$$

as claimed. ■

## V. APPROXIMATION OF THE SMOOTH PART AND THE REMAINDER

For the approximation of the smooth part  $u_S$ , and the remainder  $R_{2n}$ , we will use standard finite element spaces of piecewise polynomials. With  $\Delta = \{\Omega_\ell\}$  some subdivision of  $\Omega$ , define

$$S_N^R = \{v \in H^1(\Omega) : v|_{\Omega_\ell} \in \Pi_p(\Omega_\ell)\}, \quad (5.1)$$

and let  $v_4^N$  be the  $H^2$  projection of  $R_{2n}$  onto  $S_N^R \cap C^1(\Omega)$ . This condition ensures proper approximation of the remainder, as well as allowing us to introduce boundary correctors in the next section. Then, we have the standard  $p$  version estimate (c.f. [?])

$$\|R_{2n} - v_4^N\|_{1,\Omega} \leq Cp^{-s+1} \|R_{2n}\|_{s,\Omega},$$

with  $v_4^N = R_{2n}$  at each node of the mesh  $\Delta$ . Hence,

$$\|R_{2n} - v_4^N\|_{\varepsilon,\Omega} \leq \|R_{2n} - v_4^N\|_{1,\Omega} \leq Cp^{-s+1} \|R_{2n}\|_{s,\Omega} \leq C_s p^{-s+1} \varepsilon^{2n+1-s}, \quad (5.2)$$

where we used (??) to bound  $\|R_{2n}\|_{s,\Omega}$ .

Since  $f$  is analytic,  $u_S$  will also be analytic and, thus, (c.f. [?], [?]) there exists  $v_1^N \in S_N^R$  such that

$$\|u_S - v_1^N\|_{\varepsilon,\Omega} \leq Ce^{-ap}, \quad (5.3)$$

and  $v_1^N = u_S$  at each node of the mesh  $\Delta$ . The constants  $C, a \in \mathbb{R}$  are independent of  $p$  and  $\varepsilon$ .

## VI. FINITE ELEMENT APPROXIMATION OF $u$

We now define the space  $S_N$  to be used for the approximation of  $u = u_{2n} + R_{2n}$ , over the entire domain  $\Omega$ . We begin by defining a mesh  $\Delta$  on  $\Omega$  as follows. Let  $J_1 = (0, \kappa p \varepsilon)$ ,  $J_2 = (\kappa p \varepsilon, 1 - \kappa p \varepsilon)$ ,  $J_3 = (1 - \kappa p \varepsilon, 1)$  and define the corresponding tensor product mesh  $\{\Omega_{ij}\}_{i,j=1}^3$ ,  $\Omega_{ij} = J_i \times J_j$ , as seen in Fig. ???. Further, refine each  $\Omega_{ij}$ ,  $i, j = 1, 3$  using the geometric mesh  $\Omega_{\sigma,\nu}^k$ ,  $k = 1, \dots, 4$  given by (??). This ensures the proper approximation of the corner layers, as discussed in Section IV. Define the mesh-degree combination  $\Sigma = (\Delta, \vec{p})$ , for  $\vec{p} = (p, \dots, p)$ ,  $p > 2n$  and

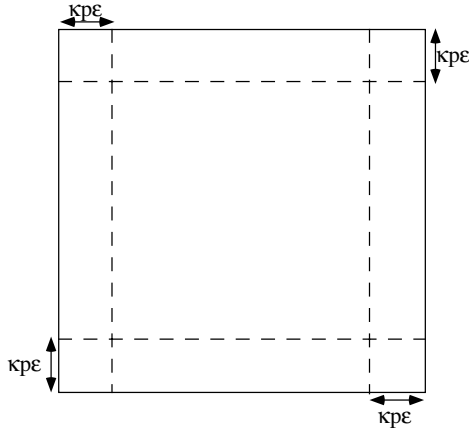
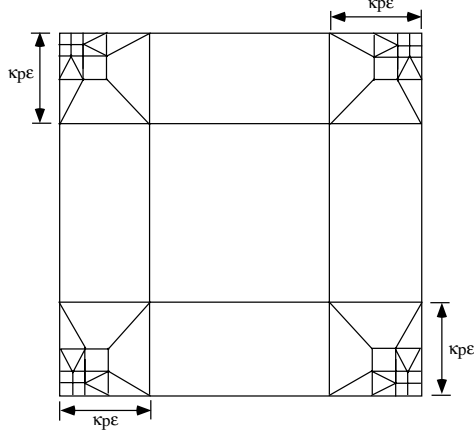

FIG. 6. Initial partition of  $\Omega$ .

FIG. 7. Final partition of  $\Omega$ .

$$\Delta = \left\{ \Omega_{ij} : \Omega_{ij} = \Omega_{\sigma, \nu(p)}^k \text{ for } i, j = 1, 3, k = 1, \dots, 4 \text{ and } \Omega_{ij} = J_i \times J_j \text{ otherwise} \right\}_{i,j=1}^3. \quad (6.1)$$

Fig. ?? illustrates this mesh. Define the finite element space

$$S_N = \{v \in H^1(\Omega) : v|_{\Omega_{ij}} \in \Pi_p(\Omega_{ij}), \Omega_{ij} \in \Delta\}, \quad (6.2)$$

and note that  $S_N^{BL} \subset S_N$ ,  $S_N^C \subset S_N$  and  $S_N^R \subset S_N$ , where  $S_N^{BL}$ ,  $S_N^C$ ,  $S_N^R$  were defined by (??), (??) and (??), respectively. Estimates (??), (??), Theorem 3.1, and Theorem 4.2 can be combined to give the following theorem.

**Theorem 6.1.** *Let  $u = u_{2n} + R_{2n}$  be the solution to (??). Then for any  $s > 0$ , there exists  $v^N \in S_N$  such that*

$$\|u - v^N\|_{\varepsilon, \Omega} \leq K\varepsilon^{1/2}p^{-s}, \quad (6.3)$$

where  $K \in \mathbb{R}$  is independent of  $\varepsilon$  and  $p$ , but depends on  $\kappa, \sigma, n$ , and  $s$ .

**Remark 6.1.** *One important observation is that the space  $S_N$ , used in the approximation of  $u \in H_0^1$ , is not a subspace of  $H_0^1$ . Thus, the best approximation (??) is not achieved using this space. This discrepancy can be corrected in two steps. First, we adjust  $v^N \in S_N$  so that  $v^N = 0$  at each node of the mesh on  $\partial\Omega$ . Then, we adjust  $v^N$  to be zero over the rest of  $\partial\Omega$ , by considering all the different types of elements in the mesh. The result of such an adjustment is stated in the following lemma. The details can be found in [?].*

**Lemma 6.1.** *For every  $v^N \in S_N$ , there exist  $w^N, V^N$  such that*

$$\hat{v}^N = (v^N - w^N - V^N) \in S_N \cap \{v : v = 0 \text{ on } \partial\Omega\} \subset H_0^1(\Omega).$$

Moreover, for any element  $S \in \Delta$ ,

$$\|w^N\|_{\varepsilon, S} \leq \tilde{C}\varepsilon^{1/2}\tilde{\beta}^p \text{ and } \|V^N\|_{\varepsilon, S} \leq C\varepsilon^{1/2-\delta}p^{-s+1+\delta}, \quad (6.4)$$

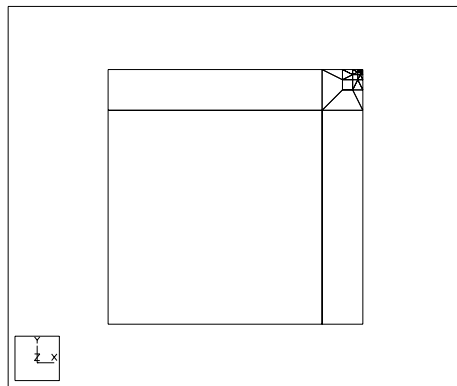

FIG. 8. The mesh for Scheme 1, with 4 layers.

where  $\tilde{C}, C \in \mathbb{R}, 0 < \tilde{\beta} < 1, \delta > 0$  and  $s > 0$  is arbitrary.

We are now in a position to present our main result.

**Theorem 6.2.** *Let  $u = u_{2n} + R_{2n}$  be the solution to (??), and  $u_N$  the solution to (??). Then for any  $\tilde{s} > 0, \delta > 0$ , there exists a constant  $K = K(\delta, \tilde{s})$  such that*

$$\|u - u_N\|_{\varepsilon, \Omega} \leq K \varepsilon^{1/2 - \delta} p^{-\tilde{s}}, \tag{6.5}$$

with  $K$  independent of  $\varepsilon$  and  $p$ .

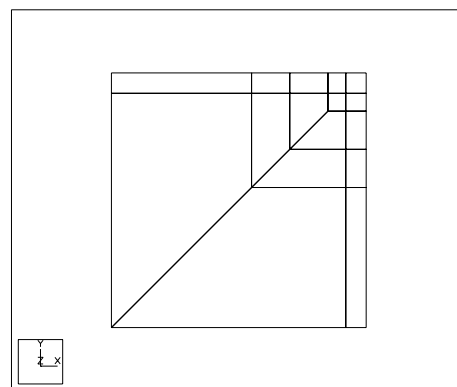

FIG. 9. The mesh for Scheme 2, with 4 layers.

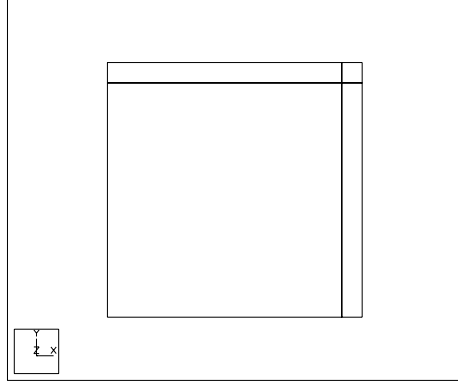

FIG. 10. The mesh for Scheme 3 (no geometric layers).

**Proof.** Follows from Theorem 6.1, Lemma 6.1, and the fact that  $u_N$  is the best approximation. ■

## VII. NUMERICAL RESULTS

In this section, we present the results of numerical computations for the model problem (??), performed using the commercial finite element package STRESSCHECK. The right-hand side  $f$  is chosen as  $f(x, y) = \exp(2 - x - y)$ . For simplicity, we will consider a quarter of the domain, with zero boundary conditions along two sides and symmetry boundary conditions along the other two sides. Due to the nature of the software package, we are not able to define a *variable* mesh on  $\Omega$ . Moreover, the maximum allowed polynomial degree is  $p_{\max} = 8$ , thus we compare four different finite element methods, based on four different meshes, as follows.

1. The first scheme consists of a geometric mesh of size  $O(p_{\max}\varepsilon)$  at the corner of the domain, with two boundary layer elements of size  $O(p_{\max}\varepsilon)$  along each side of the boundary (see Fig. ??).
2. The second scheme consists of the same combination, but now the graded mesh at the corner is *independent* of  $\varepsilon$  (see Fig. ??).
3. The third scheme consists of only the boundary layer elements of size  $O(p_{\max}\varepsilon)$ , without any geometric mesh at the corner (see Fig. ??).
4. The final scheme corresponds to the typical mesh one would use in the case where  $\varepsilon = 1$ . That is, no boundary layers are present, thus no elements of size  $O(p_{\max}\varepsilon)$  are used along the boundary, and only a graded mesh that is independent of  $\varepsilon$  is present at the corner (see Fig. ??).

We plot the relative error in the energy norm,  $E$ , given by

$$E = \frac{\|u^{EX} - u^{FEM}\|_{\varepsilon, \Omega}}{\|u^{EX}\|_{\varepsilon, \Omega}},$$

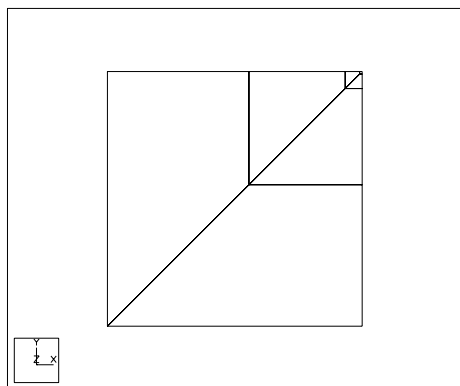

FIG. 11. The mesh for Scheme 4, with 4 layers.

versus the number of degrees of freedom,  $N$ , for  $\epsilon = 0.01, 0.001$ . Due to the fact that there is no known exact solution for this problem, we will use an “approximate exact solution,” obtained by a high-order finite element method with several thousands degrees of freedom. As can be seen in Figs. ??–??, uniform exponential convergence is visible in the first three schemes, even though, due to the technicalities in the proofs, we are able to prove only algebraic (spectral) convergence. The mesh with *no* boundary layer elements fails to capture the boundary layer effects, as expected,

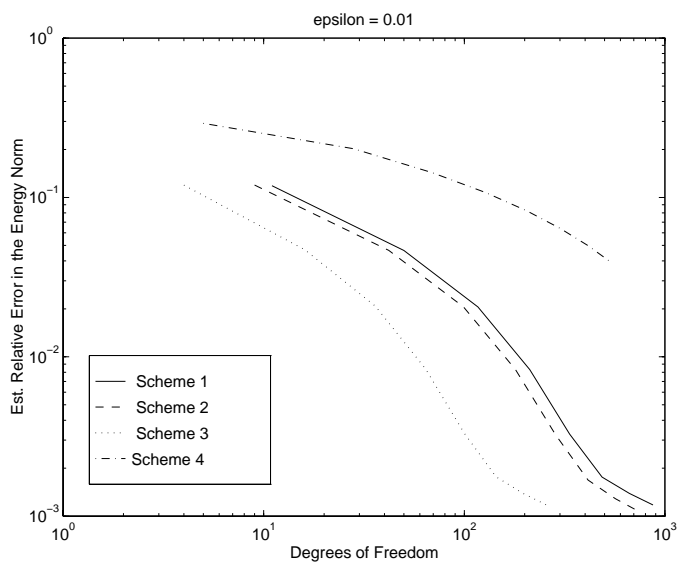

FIG. 12. Energy Norm Convergence for the four schemes.

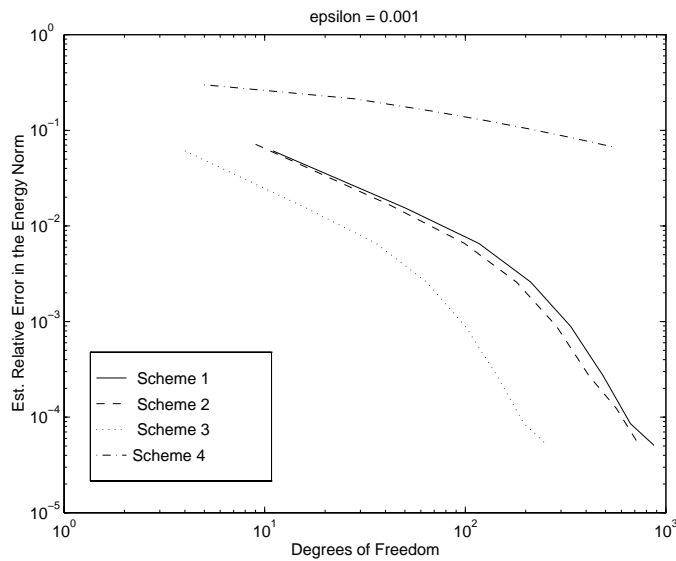

FIG. 13. Energy Norm Convergence for the four schemes.

thus no significant convergence is observed. Moreover, we note that, in practice, the geometric mesh may not be necessary for  $0 < \epsilon < 1$ , since the third scheme with *only* the boundary layer elements gives the best convergence results in the *energy norm*. (For  $\epsilon = 1$ , however, geometric refinement is necessary.) Figure ?? shows the relative error in the energy norm for Scheme 1,

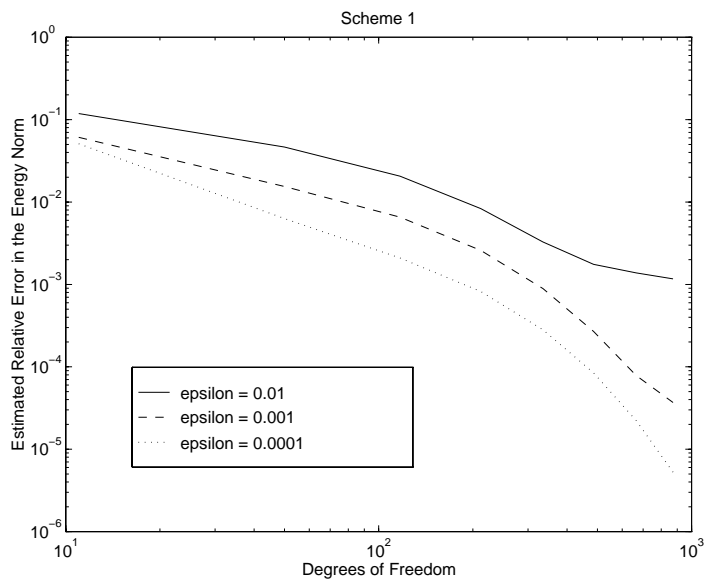

FIG. 14. Energy Norm Convergence for Scheme 1,  $\epsilon = 10^{-j}$ ,  $j = 2, 3, 4$ .

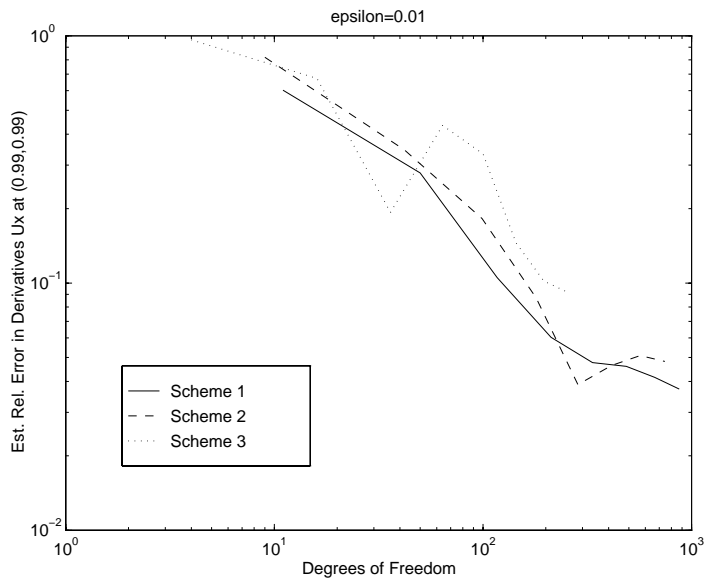

FIG. 15. Derivative Convergence at the point  $(1 - \varepsilon, 1 - \varepsilon)$ .

for different values of  $\varepsilon$ . Notice that the error decreases as  $\varepsilon \rightarrow 0$ , showing agreement with the estimate in Theorem 6.2. That is, the factor of  $\varepsilon^{1/2}$  in the estimate (??) causes the error to decrease with  $\varepsilon$ .

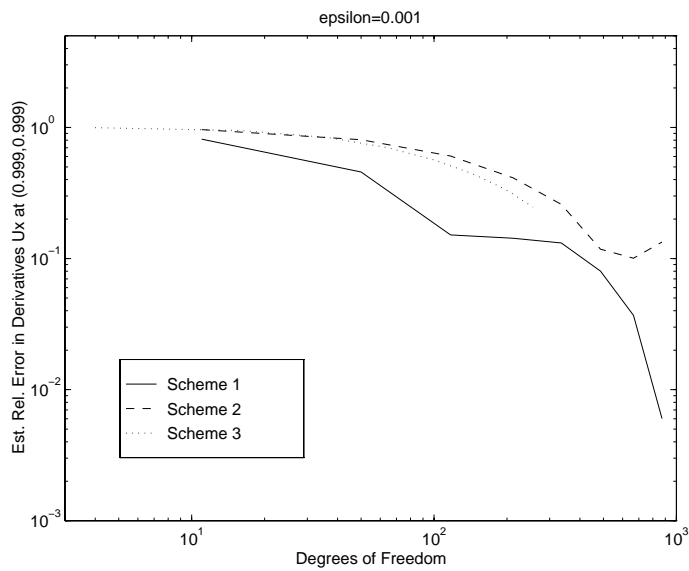

FIG. 16. Derivative Convergence at the point  $(1 - \varepsilon, 1 - \varepsilon)$ .

We also consider the error in the derivatives,

$$E' = \left[ \frac{\left| \frac{\partial u^{EX}}{\partial x} - \frac{\partial u^{FEM}}{\partial x} \right|}{\left| \frac{\partial u^{EX}}{\partial x} \right|} \right]_{(x_0, y_0)},$$

at the point  $(x_0, y_0) = (1 - \varepsilon, 1 - \varepsilon)$  for  $\varepsilon = 0.01, 0.001$ . In this case, we compare only the meshes that include boundary layer elements, as seen in Figs. ?? and ?. The first scheme seems to be the only one that yields reasonable convergence, when the *flux* at some point near the boundary is considered.

As observed from our numerical results in the case of nonsmooth domains, boundary layer and geometric refinement are required for robust convergence. Scheme 3, with only boundary layer refinement, performs well in terms of the energy norm, due to fact the singularities are mild in the case of a square domain (they essentially behave like  $(r/\varepsilon)^\alpha \log(r/\varepsilon)^\beta$ , where  $r$  is the distance from the corner). In general, boundary layer refinement alone will not be sufficient for polygonal domains with re-entrant corners. Hence, Scheme 1 should be used to capture *both* the boundary layers *and* the corner singularities, and yield good convergence results *both* in the energy norm *and* in pointwise derivative errors near the corners.

## APPENDIX

Here we present the inductive proof that establishes (??). Recall that  $v_i$  satisfies

$$\begin{aligned} -v_{i,\eta\eta} + v_i &= 0, \quad i = 0, 1, \\ -v_{i,\eta\eta} + v_i &= v_{i-2,xx}, \quad i = 2, \dots, 2n, \end{aligned} \tag{A1}$$

along with boundary conditions

$$\begin{aligned} v_i(x, 0) &= -\Delta^{(i)} f(x, 0) \\ v_i(x, \eta) &\rightarrow 0 \text{ as } \eta \rightarrow \infty, \quad i = 0, 1, \dots, 2n \end{aligned} \tag{A2}$$

where  $\eta = y/\varepsilon$ . For  $i = 0$ , we obtain

$$v_0 = -f(x, 0)e^{-\eta},$$

and for  $i$  odd,  $v_i = 0$ . Suppose, for  $i > 0$ , even, that we have

$$\begin{aligned} v_i &= e^{-\eta} \left\{ f^{(i)}(x, 0)\pi_{i/2}(\eta) + c_i \Delta^{(i)} f(x, 0) + \right. \\ &\quad \left. + \sum_{j=1}^{i/2-1} \hat{\pi}_{i/2-j}(\eta) \frac{\partial^{i-2j}}{\partial x^{i-2j}} \left( \Delta^{(2j)} f(x, 0) \right) \right\}. \end{aligned}$$

We would like to show that

$$\begin{aligned} v_{i+2} &= e^{-\eta} \left\{ f^{(i+2)}(x, 0)\pi_{i/2+1}(\eta) + c_{i+2} \Delta^{(i+2)} f(x, 0) + \right. \\ &\quad \left. + \sum_{j=1}^{i/2-1} \hat{\pi}_{i/2+1-j}(\eta) \frac{\partial^{i+2-2j}}{\partial x^{i+2-2j}} \left( \Delta^{(2j)} f(x, 0) \right) \right\}, \end{aligned}$$

where  $\pi_k(t)$  and  $\hat{\pi}_k(t)$  are polynomials of degree  $k$ . To obtain  $v_{i+2}(x, \eta)$ , we solve

$$-v_{i+2,\eta\eta} + v_{i+2} = v_{i,xx}, \tag{A3}$$

where

$$v_{i,xx} = e^{-\eta} \left\{ f^{(i+2)}(x, 0) \pi_{i/2}(\eta) + c_i \frac{\partial^2}{\partial x^2} \left( \Delta^{(i)} f(x, 0) \right) + \sum_{j=1}^{i/2} \widehat{\pi}_{i/2+1-j}(\eta) \frac{\partial^{i+2-2j}}{\partial x^{i+2-2j}} \left( \Delta^{(2j)} f(x, 0) \right) \right\}, \quad (\text{A4})$$

along with boundary conditions

$$\begin{aligned} v_{i+2}(x, 0) &= -\Delta^{(i+2)} f(x, 0) \\ v_{i+2}(x, \eta) &\rightarrow 0 \text{ as } \eta \rightarrow \infty. \end{aligned} \quad (\text{A5})$$

We use separation of variables and, with  $v_{i+2}(x, \eta) := v_{i+2}^x(x) v_{i+2}^\eta(\eta)$ , we have

$$-\frac{d^2}{d\eta^2} (v_{i+2}^\eta(\eta)) + v_{i+2}^\eta(\eta) = \frac{v_{i,xx}(x, \eta)}{v_{i+2}^x(x)}, \quad (\text{A6})$$

where  $v_{i,xx}(x, \eta)$  is given by (??).

First we solve the *homogeneous* version of (??), with boundary conditions (??), and we get  $v_{i+2}^\eta(\eta) = e^{-\eta}$  and  $v_{i+2}^x(x) = -\Delta^{(i+2)} f(x, 0)$ , so that

$$v_{i+2}(x, \eta) = -\Delta^{(i+2)} f(x, 0) e^{-\eta}. \quad (\text{A7})$$

Next, we solve the *nonhomogeneous* problem for a *particular solution*, using the *method of undetermined coefficients*. Since the right-hand side of (??), given by (??), is the sum of three terms, we solve three separate differential equations:

$$-\frac{d^2}{d\eta^2} (v_{i+2}^\eta(\eta)) + v_{i+2}^\eta(\eta) = \frac{e^{-\eta}}{v_{i+2}^x(x)} f^{(i+2)}(x, 0) \pi_{i/2}(\eta) \quad (\text{A8})$$

$$-\frac{d^2}{d\eta^2} (v_{i+2}^\eta(\eta)) + v_{i+2}^\eta(\eta) = \frac{e^{-\eta}}{v_{i+2}^x(x)} c_i \frac{\partial^2}{\partial x^2} \left( \Delta^{(i)} f(x, 0) \right) \quad (\text{A9})$$

$$-\frac{d^2}{d\eta^2} (v_{i+2}^\eta(\eta)) + v_{i+2}^\eta(\eta) = \frac{e^{-\eta}}{v_{i+2}^x(x)} \sum_{j=1}^{i/2} \widehat{\pi}_{i/2+1-j}(\eta) \frac{\partial^{i+2-2j}}{\partial x^{i+2-2j}} \left( \Delta^{(2j)} f(x, 0) \right) \quad (\text{A10})$$

**1. The solution of (??):** We choose as a particular solution

$$v_{i+2}^\eta(\eta) = \frac{f^{(i+2)}(x, 0)}{v_{i+2}^x(x)} \eta e^{-\eta} \sum_{j=0}^{i/2} \alpha_j \eta^j = \frac{f^{(i+2)}(x, 0)}{v_{i+2}^x(x)} e^{-\eta} \sum_{j=0}^{i/2} \alpha_j \eta^{j+1}, \quad (\text{A11})$$

where  $\alpha_j$  are the undetermined coefficients. Inserting (??) into (??) and equating coefficients, we obtain  $\alpha_j \neq 0, j = 0, 1, 2, \dots, i/2$ . Thus,

$$v_{i+2}^\eta(\eta) = \frac{f^{(i+2)}(x, 0)}{v_{i+2}^x(x)} e^{-\eta} \eta \pi_{i/2}(\eta) = \frac{f^{(i+2)}(x, 0)}{v_{i+2}^x(x)} \pi_{i/2+1}(\eta) e^{-\eta}. \quad (\text{A12})$$

2. **The solution of (??):** Here, we choose as a particular solution

$$v_{i+2}^\eta(\eta) = \frac{c_i}{v_{i+2}^x(x)} \frac{\partial^2}{\partial x^2} \left( \Delta^{(i)} f(x, 0) \right) (\beta_0 + \beta_1 \eta) e^{-\eta}, \quad (\text{A13})$$

where  $\beta_0, \beta_1$  are the undetermined coefficients. Inserting (??) into (??) and equating coefficients, we get  $\beta_0 = 0, \beta_1 \neq 0$ . Thus,

$$v_{i+2}^\eta(\eta) = \frac{c_i}{v_{i+2}^x(x)} \frac{\partial^2}{\partial x^2} \left( \Delta^{(i)} f(x, 0) \right) \eta e^{-\eta}. \quad (\text{A14})$$

3. **The solution of (??):** We note that since the right-hand side is a sum of  $(i/2 - 1)$  terms, we solve each differential equation separately. To this end, consider finding the solution of

$$-\frac{d^2}{d\eta^2} (v_{i+2}^\eta(\eta)) + v_{i+2}^\eta(\eta) = \frac{e^{-\eta}}{v_{i+2}^x(x)} \widehat{\pi}_{i/2+1-j}(\eta) \frac{\partial^{i+2-2j}}{\partial x^{i+2-2j}} \left( \Delta^{(2j)} f(x, 0) \right)$$

for  $j$  fixed. Let  $\Delta_{i,j}(x) := \frac{\partial^{i+2-2j}}{\partial x^{i+2-2j}} \left( \Delta^{(2j)} f(x, 0) \right)$  and choose as a particular solution

$$v_{i+2}^\eta(\eta) = \frac{e^{-\eta}}{v_{i+2}^x(x)} \Delta_{i,j}(x) \eta \sum_{\ell=0}^{i/2+1-j} \gamma_\ell \eta^\ell, \quad (\text{A15})$$

where  $\gamma_\ell, \ell = 0, \dots, i/2 + 1 - j$ , are the undetermined coefficients. Inserting (??) into (??) and equating coefficients, we obtain  $\gamma_\ell \neq 0, \ell = 0, 1, \dots, i/2 + 1 - j$ . Thus,

$$\begin{aligned} v_{i+2}^\eta(\eta) &= \frac{e^{-\eta}}{v_{i+2}^x(x)} \Delta_{i,j}(x) \eta (\gamma_0 + \gamma_1 \eta + \dots + \gamma_{i/2+1-j} \eta^{i/2+1-j}) \\ &= \frac{e^{-\eta}}{v_{i+2}^x(x)} \widehat{\pi}_{i/2+2-j}(\eta) \frac{\partial^{i+2-2j}}{\partial x^{i+2-2j}} \left( \Delta^{(2j)} f(x, 0) \right). \end{aligned}$$

Summing from  $j = 1, \dots, i/2 - 1$ , we get that the solution to (??) is given by

$$v_{i+2}^\eta(\eta) = \frac{e^{-\eta}}{v_{i+2}^x(x)} \sum_{j=1}^{i/2} \widehat{\pi}_{i/2+1-j}(\eta) \frac{\partial^{i+2-2j}}{\partial x^{i+2-2j}} \left( \Delta^{(2j)} f(x, 0) \right), \quad (\text{A16})$$

as desired.

Using the *principle of superposition*, we get that the solution to (??) is given by

$$v_{i+2}^\eta(\eta) = \frac{e^{-\eta}}{v_{i+2}^x(x)} \left\{ \pi_{i/2+1}(\eta) f^{(i+2)}(x, 0) + \sum_{j=1}^{i/2} \widehat{\pi}_{i/2+1-j}(\eta) \frac{\partial^{i+2-2j}}{\partial x^{i+2-2j}} \left( \Delta^{(2j)} f(x, 0) \right) \right\},$$

and hence,

$$v_{i+2}(x, \eta) = e^{-\eta} \left\{ \pi_{i/2+1}(\eta) f^{(i+2)}(x, 0) + \sum_{j=1}^{i/2} \widehat{\pi}_{i/2+1-j}(\eta) \frac{\partial^{i+2-2j}}{\partial x^{i+2-2j}} \left( \Delta^{(2j)} f(x, 0) \right) \right\}.$$

Adding the *homogeneous* and *particular* solutions, we get the desired result.

**References**

1. H. Han and R. B. Kellogg, "Differentiability properties of solutions of the equation  $-\varepsilon^2 \Delta u + ru = f(x, y)$  in a square," *SIAM J. Math. Anal.* 21, 394–408 (1990).
2. C. Schwab and M. Suri, "The  $p$  and  $hp$  versions of the finite element method for problems with boundary layers," *Math. Comp.* 65, 1403–1429 (1996).
3. C. Xenophontos, "The  $hp$  version of the finite element method for singularly perturbed boundary value problems in smooth domains," in *Math. Models and Methods in Applied Sciences*, Vol. 8, No. 2, 1998, pp. 299–326.
4. C. Schwab and J. M. Melenk, " $hp$  FEM for reaction-diffusion equations I: robust exponential convergence," *Seminar für Angewandte Mathematik*, ETH Zurich, Research Report No. 97–03, 1997.
5. C. Schwab and J. M. Melenk, " $hp$  FEM for reaction-diffusion equations II: regularity," *Seminar für Angewandte Mathematik*, ETH Zurich, Research Report No. 97–04, 1997.
6. I. Babuška and B. Guo, "Regularity of the solution of elliptic problems with piecewise analytic data. Part I: Boundary value problems for linear elliptic equations of second order," *SIAM J. Num. Anal.* 19, 172–203 (1988).
7. V. F. Butuzov, "The asymptotic properties of the equation  $\mu^2 \Delta u - \kappa^2(x, y)u = f(x, y)$  in a rectangle," *Differentsial'nye Uravneniya* 9, 1274–1279 (1973).
8. C. Xenophontos, "The  $hp$  version of the finite element method for singularly perturbed boundary value problems," *Doctoral Dissertation*, University of Maryland, Baltimore County, May 1996.
9. I. Babuška and B. Gui, "The  $h, p$  and  $hp$  versions of the finite element method for one dimensional problems. Part I: The error analysis for the  $p$  version," *Numer. Math.* 49, 577–612 (1986).
10. I. Babuška and B. Guo, "The  $hp$  version of the finite element method. Part I: The basic approximation results," *Comput. Mech.* 1, 21–41 (1986).
11. P. G. Ciarlet, *The Finite Element Method for Elliptic Problems*, North Holland, 1978.
12. I. Babuška and M. Suri, "The optimal convergence rate of the  $p$  version of the finite element method," *SIAM J. Num. Anal.* 24, 750–777 (1987).
13. I. Babuška and B. Szabo, *Finite Element Analysis*, John Wiley & Sons Inc., 1991.
14. C. Schwab and M. Suri, "Locking and boundary layer effects in the finite element approximation of the Riessner–Mindlin plate model," *Proc. Symp. Appl. Math* 48, 367–371 (1994).
15. C. Schwab, M. Suri, and C. Xenophontos, "The  $hp$  finite element method for problems in mechanics with boundary layers," *Comp. Meth. Appl. Mech. Eng.*, 57, 311–334 (1998).